

Premier

Manufacturers of Precision Ground Cutting Tools



Thread Whirling
simcut FX
e - Catalogue

Gewindewirbelkopf „Tornos“

Für Tornos-Maschinen.

Thread Whirling Head „Tornos“

For Tornos machines.

Anzugsmoment (Schraube) // Tightening torque (screw)

4,5 Nm



TW Legende
ST Legend

734

Scan QR-Code Oder besuchen Sie // Or Visit
www.simtek.info/cp/929



Abbildung zeigt / Drawing shows: CF5.AA40.12.06

ØDS	Anzahl Plattensitze Number of insert seats	Artikelnummer Part number	Webcode www.simtek.com/webcode	ØDa	ØDk	I	L	ØTk	Aggregat Whirling units	Schraube Screw	Schraubenschlüssel Screw driver	Connectcode www.simtek.com/code
mm				mm	mm	mm	mm	mm				
12,0	6	CF5.AA40.12.06	AS32	40,0	57,0	3,5	15,0	31,0	306101/307087	F M4x8,5 T15F	T15F	CF5.L.4.1
12,0	6	CF5.AA50.12.06	AZU8	50,0	67,0	3,5	15,4	40,0	417627	F M4x8,5 T15F	T15F	CF5.L.4.1

Bestellbeispiel // Order example: **CF5.AA50.12.06**

Befestigungsschraube // Fastening screw: D M4x12 T15F

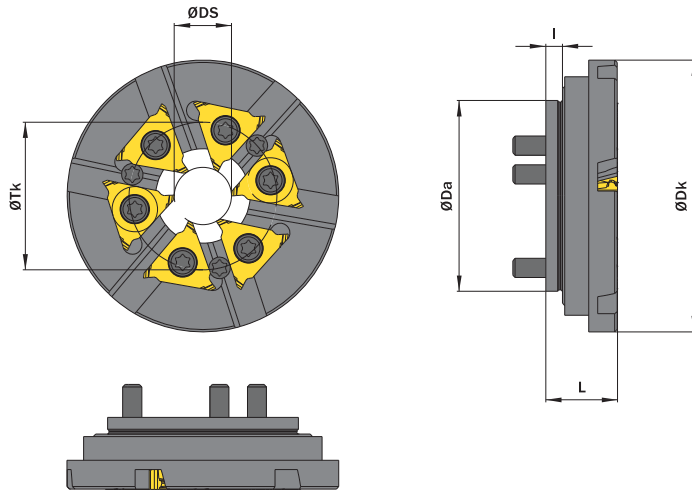
Gewindewirbelkopf „WTO“

Für WTO-Aggregate.

Thread Whirling Head „WTO“

For WTO whirling units.

Anzugsmoment (Schraube) // Tightening torque (screw)

4,5 Nm



TW Legende
ST Legend

734

Scan QR-Code

Oder besuchen Sie // Or Visit www.simtek.info/cp/933



Abbildung zeigt / Drawing shows: CF5.1242.06 W

ØDS	Anzahl Plattensitze Number of insert seats	Artikelnummer Part number	Webcode www.simtek.com/webcode	ØDa	ØDk	I	L	Aggregat Whirling units	Schraube Screw	Schraubenschlüssel Screw driver	Connectcode www.simtek.com/ccode
mm				mm	mm	mm	mm				
11,4	6	CF5.1242.06 W	AQAW	31,97	42,0	6,7	18,2	TN762004	F M4x8,5 T15F	T15F	CF5.L.4.1
20,0	8	CF5.WW54.20.08	A1F9	56,5	54,0	1,5	13,8	TN762006	F M4x8,5 T15F	T15F	CF5.L.4.1

Bestellbeispiel // Order example: **CF5.1242.06 W**

Gewindewirbelkopf „Citizen“

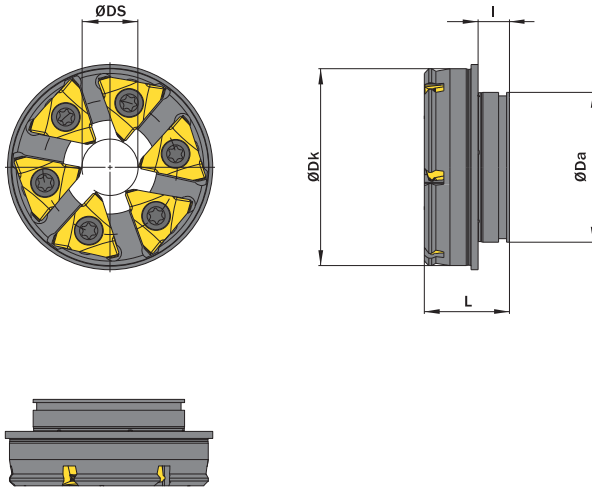
Für Citizen-Maschinen mit Citizen-Aggregat.

Thread Whirling Head „Citizen“

For Citizen machines with Citizen whirling unit.

Anzugsmoment (Schraube) // Tightening torque (screw)

4,5 Nm



TW Legende
ST Legend

734



Scan QR-Code

Oder besuchen Sie // Or Visit www.simtek.info/cp/1223



Abbildung zeigt / Drawing shows: CF5.CC33.12.06

ØDS	Anzahl Plattensitze Number of insert seats	Artikelnummer Part number	Webcode www.simtek.com/webcode	ØDa	ØDk	I	L	ØTk	Aggregat Whirling units	Schraube Screw	Schraubenschlüssel Screw driver	Connectcode www.simtek.com/code
mm				mm	mm	mm	mm	mm				
12,0	6	CF5.CC33.12.06	AZU1	33,0	46,9	4,0	18,5	40,0	BTW 1000	FM4x8,5 T15F	T15F	CF5.L.4.1

Bestellbeispiel // Order example: **CF5.CC33.12.06**

Gewindewirbelkopf „Citizen“

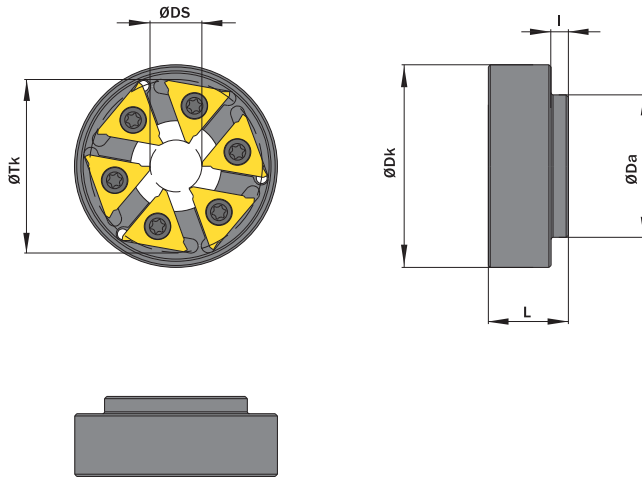
Für Citizen-Maschinen.

Thread Whirling Head „Citizen“

For Citizen machines.

Anzugsmoment (Schraube) // Tightening torque (screw)

4,5 Nm



TW
ST

Legende
Legend

734



Scan
QR-Code

Oder besuchen Sie // Or Visit
www.simtek.info/cp/926



Abbildung zeigt / Drawing shows: CF5.CP40.12.06

ØDS	Anzahl Plattensitze Number of insert seats	Artikelnummer Part number	Webcode www.simtek.com/webcode	ØDa	ØDk	I	L	ØTk	Aggregat Whirling units	Schraube Screw	Schraubenschlüssel Screw driver	Connectcode www.simtek.com/code
mm				mm	mm	mm	mm	mm				
6,0	6	CF5.CP20.06.06	A106	20,0	35,0	3,2	15,0	26,0	GSW 101	N M4x8,5 T15F	T15F	CF5.L.4.1
12,0	6	CF5.CP40.12.06	AS3Y	40,0	46,0	2,5	15,5	32,5	MWS 101; KSW 101; LSW 101; LSW 21.5315; BSW 215	N M4x8,5 T15F	T15F	CF5.L.4.1
12,0	6	CF5.CP45.12.06	A105	45,0	46,0	9,5	18,0	30,0	LSW-424	N M4x8,5 T15F	T15F	CF5.L.4.1

Bestellbeispiel // Order example: **CF5.CP40.12.06**

Befestigungsschraube // Fastening screw: D M4x12 T15F

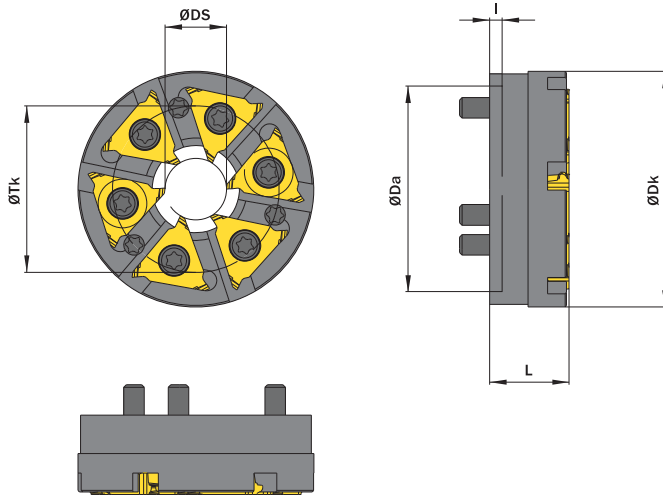
Gewindewirbelkopf „Star“

Für Star-Maschinen.

Thread Whirling Head „Star“

For Star machines.

Anzugsmoment (Schraube) // Tightening torque (screw)

4,5 Nm



TW
ST

Legende
Legend

734



Scan
QR-Code

Oder besuchen Sie // Or Visit
www.simtek.info/cp/925



Abbildung zeigt / Drawing shows: CF5.DD40.12.06

ØDS	Anzahl Plattensitze Number of insert seats	Artikelnummer Part number	Webcode www.simtek.com/webcode	ØDa	ØDk	I	L	ØTk	Aggregat Whirling units	Schraube Screw	Schraubenschlüssel Screw driver	Connectcode www.simtek.com/ccode
mm				mm	mm	mm	mm	mm				
12,0	6	CF5.DD40.12.06	AS30	40,0	47,0	7,0	15,0	33,0	5914 72 00 / 68172	NM4x8,5T15F	T15F	CF5.L.4.1

Bestellbeispiel // Order example: **CF5.DD40.12.06**

Befestigungsschraube // Fastening screw: D M4x12 T15F

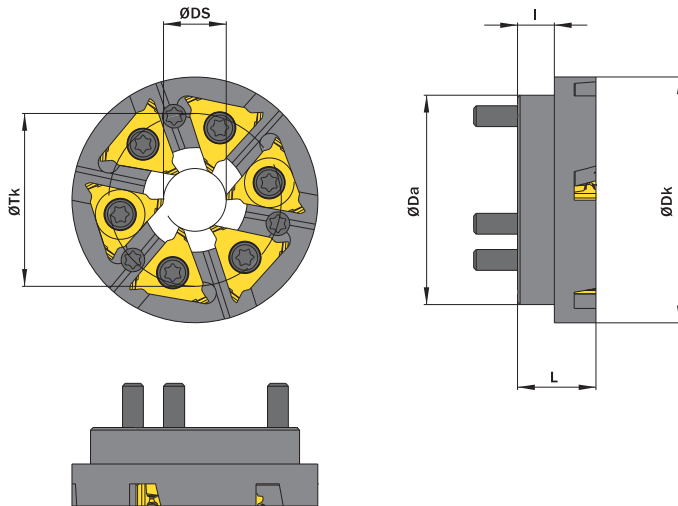
Gewindewirbelkopf „Tsugami“

Für Tsugami-Maschinen.

Thread Whirling Head „Tsugami“

For Tsugami machines.

Anzugsmoment (Schraube) // Tightening torque (screw)

“F M4x11 T15F”: 4,5 Nm
“F M4x8,5 T15F”: 4,5 Nm



TW
ST

Legende
Legend **734**



Scan
QR-Code

Oder besuchen Sie // Or Visit
www.simtek.info/cp/928



Abbildung zeigt / Drawing shows: CF5.BB52.20.06

ØDa	ØDS	Anzahl Plattensitze Number of insert seats	Artikelnummer Part number	Webcode www.simtek.com/webcode	ØDk	I	L	ØTk	Aggregat Whirling units	Schraube Screw	Schraubenschlüssel Screw driver	Connectcode www.simtek.com/code
50,0	16,0	6	CF5.BB50.16.06	A1ZF	62,0	8,5	20,0	40,0	3214 Y342	FM4x8,5T15F	T15F	CF5.L.4.1
52,0	12,0	6	CF5.BB52.12.06	AXXQ	65,0	8,7	17,0	42,0	3234 Y342	FM4x11T15F	T15F	CF5.L.4.1
52,0	12,0	6	CF5.BB52.12.10.06	A103	52,0	10,0	10,0	44,0	3268 Y452	FM4x8,5T15F	T15F	CF5.L.4.1
52,0	12,0	6	CF5.BB52.12.19.06	A1QM	54,0	6,0	19,0	38,0	3268 Y271	FM4x8,5T15F	T15F	CF5.L.4.1
52,0	20,0	6	CF5.BB52.20.06	AS31	65,0	8,7	17,0	42,0	3234 Y342	FM4x11T15F	T15F	CF5.L.4.1

Bestellbeispiel // Order example: **CF5.BB52.12.06**

Befestigungsschraube // Fastening screw: D M5x13 T20R

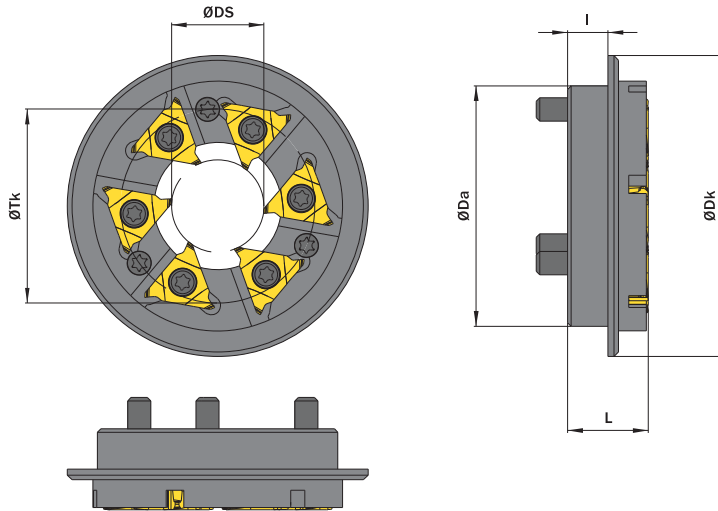
Gewindewirbelkopf „Hanwha“

Für Hanwha-Maschinen mit Madaula-Aggregat.

Thread Whirling Head „Hanwha“

For Hanwha machines with Madaula unit.

Anzugsmoment (Schraube) // Tightening torque (screw)

4,5 Nm



TW
ST

Legende
Legend

734



Scan
QR-Code

Oder besuchen Sie // Or Visit
www.simtek.info/cp/1176



Abbildung zeigt / Drawing shows: CF5.FM45.12.06

ØDS	Anzahl Plattensitze Number of insert seats	Artikelnummer Part number	Webcode www.simtek.com/webcode	ØDa	ØDk	I	L	ØTk	Schraube Screw	Schraubenschlüssel Screw driver	Connectcode www.simtek.com/ccode
mm				mm	mm	mm	mm	mm			
12,0	6	CF5.FM45.12.06	AZCQ	45,0	56,0	8,5	15,0	31,2	FM4x8,5 T15F	T15F	CF5.L.4.1

Bestellbeispiel // Order example: **CF5.FM45.12.06**

Befestigungsschraube // Fastening screw: D M4x12 T15F

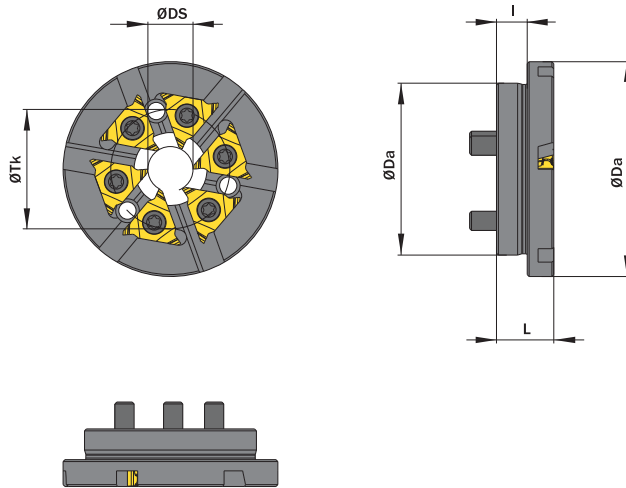
Gewindewirbelplatten

Gewindewirbelplatten für HA-Gewinde.

Thread Whirling inserts

Thread whirling inserts for HA-threads.

Schnittwerte (Start) // Cutting parameters (start) **Vc**
Seite/Page 696

Passende Klemmhalter auf Seite // Suitable toolholders on page
699, 700, 701, 702, 703, 704, 705



SP Legende
HM Legend **734**

Scan QR-Code Oder besuchen Sie // Or Visit
www.simtek.info/cp/916

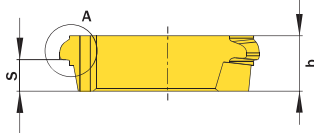
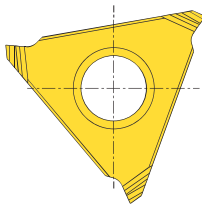

Detail A (20 : 1)

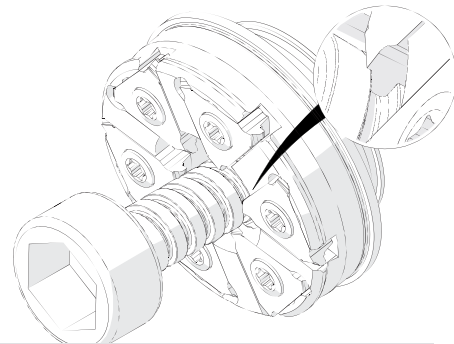
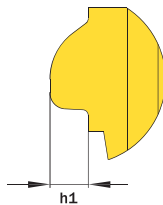

Illustration zeigt beispielhafte Anwendungsmöglichkeit mit ähnlichem Werkzeug.
Image shows exemplary application possibility with similar tool.

Abbildung zeigt / Drawing shows: CF5.175.HA.02 M

Steigung (von) Pitch (as of)	Artikelnummer Part number	Webcode www.simtek.com/webcode	Schneidstoffgruppe Cutting Grade Group	b	h1	S	Connectcode www.simtek.com/ccode
				mm	mm	mm	
0,5	CF5.050.HA.02 M	AUK5	CH G F K	4,1	0,19	3,5	CF5.L.4.1
0,6	CF5.060.HA.02 M	AUK6	CH G F K	4,1	0,34	3,5	CF5.L.4.1
1,0	CF5.100.HA.02 M	AUK7	CH G F K	4,1	0,4	3,1	CF5.L.4.1
1,25	CF5.125.HA.02 M	AUK8	CH G F K	4,1	0,55	2,8	CF5.L.4.1
1,5	CF5.150.HA.02 M	AS3P	CH G F K	4,1	0,55	2,5	CF5.L.4.1
1,75	CF5.175.HA.02 M	AS3Q	CH G F K	4,1	0,75	2,3	CF5.L.4.1

Bestellbeispiel // Order example: **CF5.100.HA.02 M X800** (X800 = Schneidstoff // Grade)

Gewindewirbelplatte

Gewindewirbelplatten für HB-Gewinde.

Thread Whirling inserts

Thread whirling inserts for HB-threads.

Schnittwerte (Start) // Cutting parameters (start) **Vc**
Seite/Page 696

Passende Klemmhalter auf Seite // Suitable toolholders on page
699, 700, 701, 702, 703, 704, 705

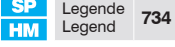

 Legende // Legend **734**
 Scan QR-Code // Oder besuchen Sie // Or Visit www.simtek.info/cp/919

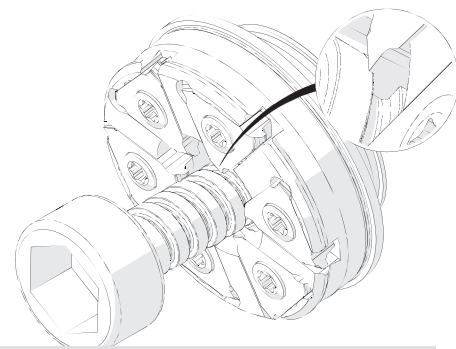
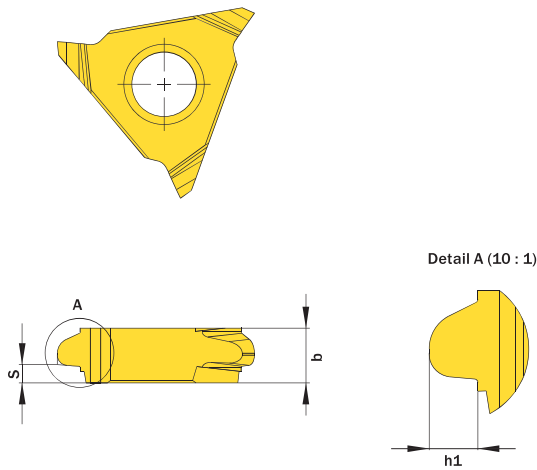

Illustration zeigt beispielhafte Anwendungsmöglichkeit mit ähnlichem Werkzeug.
Image shows exemplary application possibility with similar tool.

Abbildung zeigt / Drawing shows: CF5.275.HB.02 M

Steigung (von) Pitch (as of)	Artikelnummer Part number	Webcode www.simtek.com/webcode	Schneidstoffgruppe Cutting Grade Group	b	h1	s	Connectcode www.simtek.com/ccode
				mm	mm	mm	
1,75	CF5.175.HB.02 M	AS3S	CHGFK	4,1	1,05	2,35	CF5.L.4.1
2,75	CF5.275.HB.02 M	AS3T	CHGFK	4,1	1,75	1,4	CF5.L.4.1

Bestellbeispiel // Order example: **CF5.175.HB.02 M X800** (X800 = Schneidstoff // Grade)

Gewindewirbelplatten, metr. ISO

Gewindewirbelplatten für metrische ISO-Gewinde, Vollprofil. Für Gewinde der Toleranzklasse 6H/6g.

Thread Whirling Inserts, metr. ISO

Thread whirling inserts for metric ISO-threads, full profile. For threads with tolerance class 6H/6g.

Schnittwerte (Start) Vc
Cutting parameters (start) **Seite/Page 696**

Passende Klemmhalter auf Seite // Suitable toolholders on page
699, 700, 701, 702, 703, 704, 705

Bitte Hinweise im Anhang beachten // Please read add. notes

Wichtige Hinweise // Important hints (Seite/Page 733)



SP Legende
HM Legend **734**

Scan QR-Code Oder besuchen Sie // Or Visit
www.simtek.info/cp/1328



Abbildung zeigt / Drawing shows: CF5.060.MT.02 M

h3	Steigung (von Pitch (as of)	Artikelnummer Part number	Webcode www.simtek.com/webcode	Schneidstoffgruppe Cutting Grade Group	b	R	S	PDX	Connectcode www.simtek.com/ccode	
mm	mm				mm	mm	mm	mm		
0,31	0,5	CF5.050.MT.02 M	A28M	CHGFK	4,1	0,06	3,94	0,45	CF5.L.4.1	new
0,37	0,6	CF5.060.MT.02 M	A28N	CHGFK	4,1	0,08	3,94	0,5	CF5.L.4.1	new
0,43	0,7	CF5.070.MT.02 M	A28P	CHGFK	4,1	0,09	3,93	0,55	CF5.L.4.1	new
0,49	0,8	CF5.080.MT.02 M	A28Q	CHGFK	4,1	0,1	3,93	0,6	CF5.L.4.1	new
0,61	1,0	CF5.100.MT.02 M	A28S	CHGFK	4,1	0,12	3,94	0,65	CF5.L.4.1	new
0,77	1,25	CF5.125.MT.02 M	A5EN	CHGFK	4,1	0,16	3,94	0,77	CF5.L.4.1	new
0,92	1,5	CF5.150.MT.02 M	A5EQ	CHGFK	4,1	0,19	3,94	0,9	CF5.L.4.1	new

Bestellbeispiel // Order example: **CF5.100.MT.02 M HX79** (HX79 = Schneidstoff // Grade)

Halbzeuge

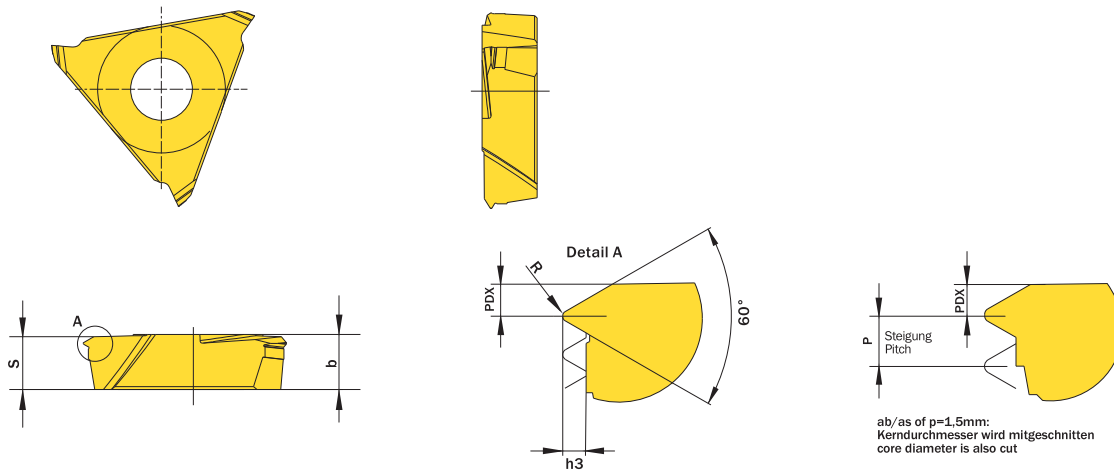
CF5-Halbzeuge für komponenten- und kundenspezifische Formen.

Semi-Finished Inserts

Semi-finished-insert for component- and customer-specific forms.

Schnittwerte (Start) // Cutting parameters (start) Vc **Seite/Page 696**

Passende Klemmhalter auf Seite // Suitable toolholders on page **699, 700, 701, 702, 703, 704, 705**

	SP	Legende	734
	HM	Legende	
	Scan QR-Code	Oder besuchen Sie // Or Visit www.simtek.info/cp/932	



Abbildung zeigt / Drawing shows: CF5.0410.00 M

b	Artikelnummer Part number	Webcode www.simtek.com/webcode	Schneidstoffgruppe Cutting Grade Group	ØIK	Connectcode www.simtek.com/ccode
mm				mm	
4,1	CF5.0410.00 M	AS1N	CH G F K	9,5	CF5.L.4.1
5,5	CF5.0550.00 M	AS1P	CH G F K	9,5	CF5.L.4.1

Bestellbeispiel // Order example: **CF5.0550.00 M GF25** (GF25 = Schneidstoff // Grade)

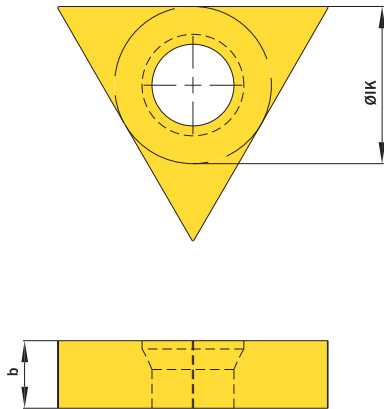

Manufacturers of Precision Ground Cutting Tools

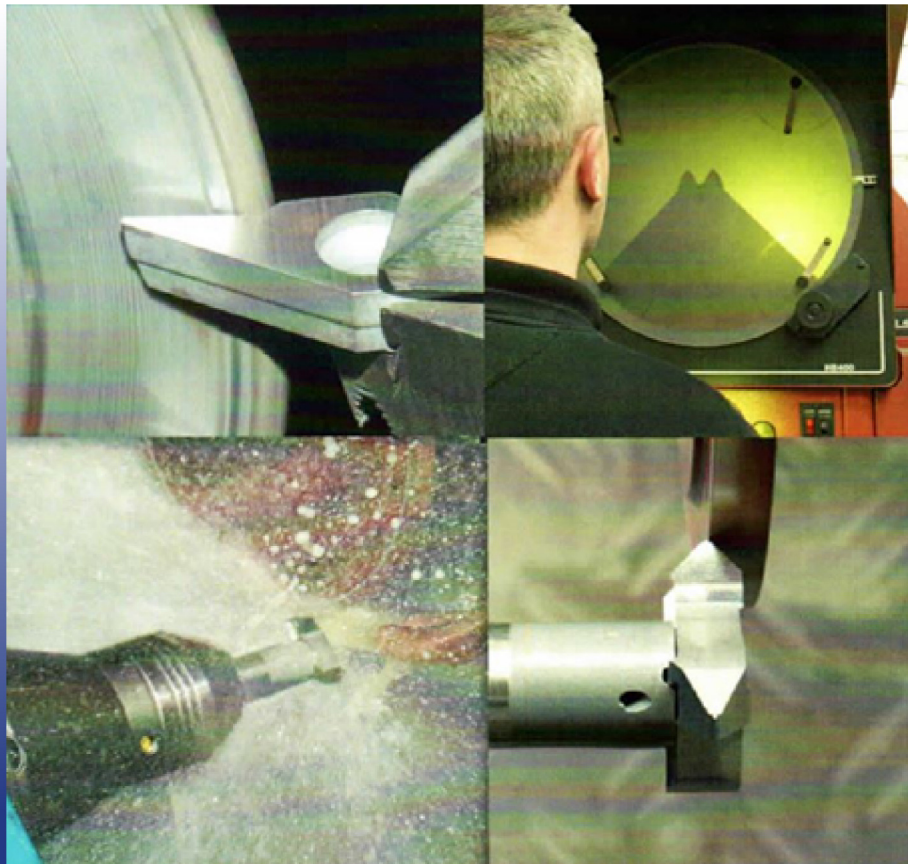

Premier Form Tools Ltd

Lancaster Road, Bowerhill, Melksham, Wiltshire, SN12 6SS, UK

Tel: +44 (0)1225 702584 Fax: +44 (0)1225 790026

e-mail: enquiries@premierformtools.co.uk

Full details of our products are available at
www.premierformtools.co.uk